

# CEMA WORKING PAPER SERIES

## **Evolution of Transitory Volatility over the Week**

Charles Cao

Department of Finance, Smeal College of Business Administration  
Pennsylvania State University  
University Park, PA 16802

Hyuk Choe

College of Business Administration  
Seoul National University

Working Paper 4

May 1999

## Evolution of Transitory Volatility over the Week

Charles Cao\*

*Department of Finance, Smeal College of Business Administration  
Pennsylvania State University  
University Park, PA 16802*

E-mail: charles@loki.smeal.psu.edu

and

Hyuk Choe

*College of Business Administration  
Seoul National University*

E-mail: hchoe@plaza.snu.edu

This study examines the evolution of transitory volatility over the week for NYSE/AMEX stocks. We treat the block of five trading days during a week as a single trading session and control for disproportionate rates of information arrival over the week by comparing variances of weekly returns measured on different days of the week. Our evidence, from both portfolios and individual stocks, is largely consistent with the implications of price formation models. We find that prices on Mondays contain significantly greater transitory volatility than prices on the other days of the week. Transitory volatility declines steadily over the week. Cross-sectionally, the speed and magnitude of dissipation of transitory volatility are greater for larger firms. Portfolio returns exhibit a much stronger pattern, suggesting that much of transitory volatility varying in the process of price formation is not diversifiable. Similar evidence is obtained from our analyses of the Dow Jones Index, the S&P 500 index futures and the Japanese Nikkei 225 Index.

*Key Words:* Transitory volatility; Price formation; Exogenous liquidity demand.

*JEL Classification Number:* G10.

\*We are grateful to Jim Angel, Tim Bollerslev, Frank Hatheway, Avner Kalay, Donald Keim, Bill Kracaw, Ananth Madhavan, Harold Mulherin, Cathy Niden, Dennis Sheehan and seminar participants at Georgetown University, Penn. State University, University of Notre Dame, and University of Utah for helpful comments.

## 1. INTRODUCTION

A central theme of market microstructure analysis is the role of trading in the process of security price formation. Models of price formation suggest that the opening price of a trading session after a long nontrading period contains greater transitory volatility than the closing price.<sup>1</sup> The reason is that the preceding nontrading period hinders the process of price formation in which trading itself plays an important role. Consistent with this implication, there is mounting evidence that daily opening prices contain greater transitory volatility than closing prices. Examples for the U.S. stock markets include Amihud and Mendelson (1987), Stoll and Whaley (1990) and Gerety and Mulherin (1994) for NYSE stocks and Cao, Choe and Hatheway (1994) for NASDAQ stocks. A similar pattern is found for stocks traded on exchanges in other nations.<sup>2</sup>

This study expands the price formation literature by examining the evolution of transitory volatility during the week. In essence, we treat the block of five trading days during a week as a single trading session. Because a long nontrading period precedes each block of five trading days, we expect that the aforementioned empirical evidence on daily opening prices may extend to the weekly level. That is, we expect that transitory volatility contained in Monday prices is greater than that in prices on the other weekdays.

In price formation models, such as those developed by Grundy and McNichols (1989), Brown and Jennings (1989), Blume, Easley and O'Hara (1994) and Shalen (1993), prices are noisy signals of the underlying asset value, and multiple rounds of trading are necessary for prices to be fully revealing. Gerety and Mulherin (1994) argue that if overnight nontrading is an important hindrance to price formation, prices become progressively less noisy as trading proceeds during the following day. Consistent with this implication, they find that transitory volatility contained in the Dow Jones Index steadily declines during the day. The Gerety and Mulherin hypothesis can be extended directly to the weekly level: transitory volatility declines steadily throughout the week.

The validity of this hypothesis depends crucially on the speed of transitory volatility dissipation. For example, if trading on Mondays is frequent enough to dissipate transitory volatility induced by weekend nontrading, we would expect (i) transitory volatility is the greatest at the opening on Mondays but it should be constant at the openings on the other days, and

---

<sup>1</sup>Transitory volatility is defined as variance in excess of that generated by information flow. It is induced by the difference between the observed price and the efficient price, where the latter is the price implied by weak-form market efficiency.

<sup>2</sup>These studies include Amihud and Mendelson (1991) for the Japanese stock market, Masulis and Ng (1992) for the U.K. stock market and Choe and Shin (1993) for the Korean stock market.

(ii) transitory volatility contained in the closing prices should be constant across all weekdays. On the other hand, if a portion of transitory volatility induced by weekend nontrading is carried over to the following days, we would expect that transitory volatility at the close as well as at the open will steadily decline over the week.

It should be emphasized that the well-known empirical fact that daily return variance is greater on Mondays than on the other days of the week (French (1980) and Keim and Stambaugh (1984)) does not imply greater transitory volatility in Monday prices. In fact, comparing daily return variances across days of the week does not offer much insight into the relative magnitudes of transitory volatility because differences in daily return variances may also be due to disproportionate rates of public and private information arrival over days of the week. To gauge the relative magnitudes of transitory volatility, the flow of information should be kept constant throughout the week. In this study, we compare variances of seven-day returns measured on different days of the week. Variances of “efficient” returns of Monday-to-Monday, Tuesday-to-Tuesday, . . . , and Friday-to-Friday are identical in the long run because they must reflect the same rate of information flow. Thus, any differences in seven-day variances among days of the week should be attributed to differences in transitory volatility.<sup>3</sup>

We begin our analysis by examining the NYSE/AMEX size decile portfolios and value- and equal-weighted market portfolios for the period 1963–1992. The major findings are the prices on Mondays contain significantly greater transitory volatility than prices on the other days of the week, and transitory volatility steadily declines over the week. For example, our GMM estimates show that Monday-to-Monday returns are more volatile than Friday-to-Friday returns by 24% to 30%. We find similar results for returns of the Dow Jones Index (1897–1990) and of the Nikkei 225 Index (1973–1992). Our evidence from portfolios is interesting because portfolio returns are not likely to be affected by firm-specific frictions such as price discreteness (Harris (1990)) and bid-ask bounce (Roll (1984)). However, portfolio returns are subject to the nonsynchronous trading problem (Scholes and Williams (1977)). To address this issue, we examine the S&P 500 Index futures. Since it is an individual security, it is not subject to the nonsynchronous trading problem. The results for the S&P 500 index futures are similar to those for portfolios, suggesting the steadily declining pattern in transitory volatility is not due to nonsynchronous trading.

The evidence from individual stocks shows a similar declining pattern in transitory volatility over the week. In addition, the magnitude of dissipation of transitory volatility is much greater for large firms than for small

---

<sup>3</sup>Our approach is identical to the one used by Amihud and Mendelson (1987) and Stoll and Whaley (1990), who compare open-to-open and close-to-close daily return variances. The underlying logic is also identical.

firms. The difference between Monday-to-Monday and Friday-to-Friday return variances is 10.2% for stocks in the largest capitalization decile. In contrast, the difference is only 3.8% for stocks in the smallest decile.

The evidence documented in this paper is consistent with the implications of price formation models. It indicates that transitory volatility induced by weekend nontrading is in part carried over to the following day. Furthermore, much of firm-specific transitory volatility is not diversifiable.

The remaining sections are organized as follows. In Section II, we provide an operational definition of transitory volatility and develop an empirically testable hypothesis. The empirical method used is described in Section III. The data is described in Section VI. Sections V and VI present evidence that supports our hypothesis. Section VII provides concluding remarks.

## 2. SOURCES OF TRANSITORY VOLATILITY

By transitory volatility, we mean variance in excess of that generated by information flow. Specifically, we model the observed price at time  $t$  as the sum of the true price,  $p_t^*$ , and the noise,  $u_t$ :<sup>4</sup>

$$p_t = p_t^* + u_t. \quad (1)$$

This decomposition of the observed price is the same as in Amihud and Mendelson (1987) and Stoll and Whaley (1990). The market maker forms an expectation of the share value conditional on his information set.<sup>5</sup> The variable  $p_t^*$  represents this conditional expectation, and its change is serially uncorrelated.

In this simple model, the observed price may deviate from the true price due to various frictions which are compactly summarized by  $u_t$ . These frictions include temporal aberration of prices due to the existence of traders endowed with heterogeneous beliefs, the impacts of temporary order flow imbalances caused by exogenous demand shocks, the discreteness of price movements, and the response of monopolistic specialists. In the context of this study, we refer to models of price formation as models that are primarily concerned with the intertemporal behavior of  $u_t$  induced by heterogeneous belief. Since there is no conceivable reason for the last two frictions to differ across days of the week, discussions in the following subsections are confined to the temporal behavior of the first two.

---

<sup>4</sup>We use logarithmic prices throughout this paper.

<sup>5</sup>Market makers need not be specialists on the exchange. As in Grossman and Miller (1988) and Campbell, Grossman and Wang (1993), any liquidity supplier who is willing to accommodate fluctuations in the liquidity demand can be thought of as a market maker. Thus, we use the terms market makers and liquidity suppliers interchangeably.

### 2.1. Information asymmetry and heterogeneous beliefs

Bagehot (1971) was one of the first to recognize that information asymmetry among investors induces an adverse selection problem. Kyle (1985) formalized the notion of adverse selection in security markets, which has since been extended by numerous authors. In Kyle-type models, the market maker cannot distinguish between informed and uninformed traders. Thus, prices are not fully revealing, and therefore, slowly incorporate private information as multiple rounds of trading take place. In this sense, prices are noisy signals for private information. However, it is important to recognize that the noise contained in a price is different from our  $u_t$ . While our  $u_t$  is the deviation of the observed price from an unbiased estimate of the true share value conditional on the market maker's information set, the noise in Kyle-type models represents the deviation of the true share value from the unbiased estimate. Thus, our  $u_t$  implies systematic reversion of prices, but the noise arising from Kyle-type models does not.

Unlike the Kyle-type models, the growing literature of noisy rational expectations models is mostly concerned with the nonstrategic behavior of heterogeneously informed traders.<sup>6</sup> A typical assumption is that the aggregate supply of securities is uncertain. In these models, prices are noisy signals of the underlying asset value. Thus, a single price does not impound all private information, and multiple rounds of trading are necessary for prices to be fully revealing. Recent examples of such models include Grundy and McNichols (1989), Brown and Jennings (1989), Blume, Easley and O'Hara (1994) and Shalen (1993).<sup>7</sup>

In particular, Shalen derives an explicit relation between return variance and the dispersion of beliefs. She suggests that since information is more diffuse at the open after an overnight trading break, dispersion of beliefs among investors tends to be the greatest at this time. Thus, the level of noise is likely to be the greatest at the open. As trading proceeds during the trading session, more information is revealed through prices. Eventually, investors' beliefs converge through this learning process.

### 2.2. Exogenous liquidity demand

While this paper focuses on implications of price formation models, the existence of noninformational traders may also be a source of transitory volatility. These investors desire to buy or sell for exogenous reasons.

---

<sup>6</sup>In noisy rational expectations models, it is standard that divergent beliefs are the result of private information that differs across investors. In a recent article, Harris and Raviv (1993) deviate from this standard approach. They analyze a situation in which investors receive common information but disagree upon the meaning of this information.

<sup>7</sup>Unlike most of other studies, Blume, Easley and O'Hara assume that aggregate supply of securities is fixed. They argue that trading volume conveys additional information that is not impounded in prices.

Other investors who are risk-averse liquidity suppliers require compensation for accommodating liquidity demand. Thus, as Campbell, Grossman and Wang (1993) argue, price changes, especially those accompanied by large order imbalances, tend to be reversed later.

Transitory volatility caused by shifts in the liquidity demand may vary systematically across times of the day or across days of the week. In particular, Brock and Kleidon (1992) argue that some investors may have incentives to bunch up at the open and the close of a trading session because of an inability to trade during periodic market closure. At the open, investors' portfolios are likely to be suboptimal because of the accumulation of information during the prior nontrading period. At the close, investors may have incentives to adjust their portfolios in anticipation of the pre-scheduled trading halt. The existence of institutionalized procedures, such as "at the opening" and "market-on-close" orders, signifies the importance of these two particular time points. Since the liquidity demand of these investors is higher and less elastic at the open and close, liquidity suppliers will charge a higher price, which causes greater transitory volatility. The same logic dictates that transitory volatility, caused by such exogenous liquidity demand, should be the greatest on Mondays and Fridays because of the long market closure over the weekend. Thus, the predicted pattern of transitory volatility over days of the week is different from a steadily declining pattern predicted by price formation models. The Brock and Kleidon model implies a U-shape rather than a steady decline pattern.

The existing empirical evidence on the Brock and Kleidon model is, however, mixed. Jain and Joh (1988) find that, while trading volume is the greatest at the open and the close of a trading day, trading volume is the lowest on Mondays. Thus, intraday patterns of trading volume are consistent with the exogenous liquidity demand model, but weekly patterns are not. Further, Lakonishok and Maberly (1990) find that trading activity by institutional investors is lower on Mondays than on other days of the week. In this paper, we test implications of price formation models and the exogenous liquidity demand model by examining transitory volatility over the week.

### 3. EMPIRICAL METHODS

#### 3.1. Measuring transitory volatility

To estimate variances of weekly returns, we first calculate five seven-day returns  $r_t^k$  for each calendar week  $t$ , i.e.,

$$r_t^k \equiv p_t^k - p_{t-1}^k,$$

where  $k = 1, 2, \dots, 5$  represents Monday, Tuesday,  $\dots$ , and Friday, respectively, and  $p_t^k$  represents the logarithmic price on the day. The observed stock price,  $p_t^k$ , is decomposed into the true price,  $p_t^{*k}$ , and the noise,  $u_t^k$ . Thus, the observed seven-day return on day  $k$  can be restated as

$$r_t^k = r_t^{*k} + u_t^k - u_{t-1}^k, \quad (2)$$

where  $r_t^{*k}$  ( $\equiv p_t^{*k} - p_{t-1}^{*k}$ ) is the true return. Then, the variance of the observed seven-day return is<sup>8</sup>

$$\text{Var}(r_t^k) = \text{Var}(r_t^{*k}) + \text{Var}(u_t^k - u_{t-1}^k) + 2\text{Cov}(r_t^{*k}, u_t^k - u_{t-1}^k). \quad (3)$$

The true price,  $p_t^{*k}$ , is the expectation of the true share value conditional on all public information available at time  $t$ . We assume that the unobservable true return,  $r_t^{*k}$ , is serially independent.<sup>9</sup> Given this assumption, the true return variance,  $\text{Var}(r_t^{*k})$ , should be constant across  $k$ 's, because this is the sum of five variances of daily efficient returns. Thus, any differences in the observed variances of seven-day returns across days of the week must be due to differences in transitory volatility represented by the second and third terms rather than due to disproportionate rates of information arrival over days.

In this paper, we use the following variance ratio to assess the relative importance of transitory volatility across days of the week:

$$\text{VR}(k) = \text{Var}(r^k)/\text{Var}(r^5), \quad k = 1, 2, 3, \text{ and } 4. \quad (4)$$

That is, we use the variance of Friday-to-Friday returns as the benchmark.

The above framework can be used for portfolios as well. To understand this, rewrite equation (1) for stock  $i$  as

$$r_{it}^k = r_{it}^{*k} + u_{it}^k - u_{i,t-1}^k. \quad (5)$$

Analogous to the standard one factor model, we can decompose the true return into the market component,  $r_{mt}^{*k}$ , and the firm-specific component,  $\nu_{it}^{*k}$ :  $r_{it}^{*k} = \beta_i r_{mt}^{*k} + \nu_{it}^{*k}$ , where  $\beta_i$  is a time invariant market sensitivity coefficient for stock  $i$ . We also decompose the noise into market-wide noise,  $\epsilon_{mt}^k$ , and the idiosyncratic noise,  $\epsilon_{it}^k$ :  $u_{it}^k = \beta_i \epsilon_{mt}^k + \epsilon_{it}^k$ .<sup>10</sup> Thus, we can write equation (5) as

$$r_{it}^k = \nu_{it}^{*k} + \beta_i r_{mt}^{*k} + \beta_i (\epsilon_{mt}^k - \epsilon_{m,t-1}^k) + (\epsilon_{it}^k - \epsilon_{i,t-1}^k). \quad (6)$$

<sup>8</sup>We leave time subscripts  $t$  in the variance equation to make the lag structure clear.

<sup>9</sup>This assumption reflects the standard notion of weak-form market efficiency. However, it is stricter than necessary. The entire argument still holds as long as the serial correlation in daily "true" returns is constant across days of the week.

<sup>10</sup>The market-wide noise may arise from heterogeneous beliefs regarding market-wide information, or from exogenous liquidity demand for securities with market risk.



Since the firm specific component of a reasonably well-diversified portfolio is negligible, we have

$$r_{mt}^k = r_{mt}^{*k} + \epsilon_{mt}^k - \epsilon_{m,t-1}^k,$$

where  $r_{mt}^k$  is the return on the diversified portfolio. This equation is identical to equation (1).

### 3.2. Statistical issues

There are at least three statistical issues that are important for our tests. First, means of variance ratios are upward biased due to Jensen's inequality. Second, Ronen (1994) and Jones and Kaul (1994) argue that standard test statistics for variance ratios may be inappropriate due to cross-sectional dependence. The idea is that even though the majority of sample firms exhibit variance ratios greater than one, it cannot be interpreted as strong evidence against the null because stock returns are cross-correlated. Third, the standard  $F$ -test for testing the equality of seven-day return variances measured on different days of the week breaks down since the numerator and denominator share some common observations. Gerety and Mulherin (1994) conduct a simulation, and conclude that these overlapping observations may cause the standard  $F$ -test to fail to reject the null hypothesis.

Our empirical tests are designed to alleviate these problems. For the analysis of portfolios and index futures, we use the generalized method of moment approach to estimate variance ratios and test the hypothesis. For the analysis of individual stocks, we use a test based on cross-sectional median variance ratios.

### 3.3. Generalized Method of Moments approach

This section describes a procedure to estimate the variance ratio and test the null hypothesis that variances of weekly returns measured on different days of the week are equal. For the analysis of portfolios and index futures, we use Hansen's (1982) Generalized Method of Moments (GMM) approach.<sup>11</sup> This approach generates an asymptotically efficient estimate of the covariance matrix of parameters without requiring that stock returns be normal. In addition, it takes into account of autocorrelations and heteroskedasticity in an intuitive way. Furthermore, it is easy to test over-identified moment restrictions, such as the equality of seven-day variances measured on different days of the week.

We are interested in estimating the parameter vector,

$$\theta \equiv (\mu_1, \mu_2, \mu_3, \mu_4, \mu_5, \text{VR}(1), \text{VR}(2), \text{VR}(3), \text{VR}(4), \sigma_5^2)',$$

<sup>11</sup>Richardson and Smith (1991), Ronen (1994) and Smith (1994) suggest the use of the GMM approach to account for overlapping data.

where  $\mu_i$  is the unconditional mean of day i-to-day i return,  $\sigma_5^2$  is the unconditional variance of Friday-to-Friday returns.

Consider the following GMM disturbance term,

$$f_t(\theta) \equiv \begin{pmatrix} r_t^1 - \mu_1 \\ r_t^2 - \mu_2 \\ r_t^3 - \mu_3 \\ r_t^4 - \mu_4 \\ r_t^5 - \mu_5 \\ (r_t^1 - \mu_1)^2 - VR(1) \cdot \sigma_5^2 \\ (r_t^2 - \mu_2)^2 - VR(2) \cdot \sigma_5^2 \\ (r_t^3 - \mu_3)^2 - VR(3) \cdot \sigma_5^2 \\ (r_t^4 - \mu_4)^2 - VR(4) \cdot \sigma_5^2 \\ (r_t^5 - \mu_5)^2 - \sigma_5^2 \end{pmatrix},$$

and the corresponding moment restrictions,

$$E[f_t(\theta)] = 0. \tag{7}$$

Since the number of parameters equals the number of restrictions, the above system is just identified.

The idea of the GMM is to approximate the moment restrictions in (7) with the sample mean  $g_T(\theta) = \frac{1}{T} \sum_{t=1}^T f_t(\theta)$  by minimizing a quadratic form  $g_T' W g_T$  with  $W$  being the weighting matrix and  $T$  the number of observations in the time series. Hansen (1982) shows that the GMM estimators are asymptotically normally distributed and the asymptotic variance-covariance matrix of the GMM estimator  $\hat{\theta}$  is given by  $(D_0 S_0^{-1} D_0)^{-1}$  with  $D_0 = E[\frac{\partial g_T}{\partial \theta}]$  and  $S_0 = W^{-1} = \sum_{l=-\infty}^{+\infty} E[f_t \cdot f_{t-l}']$ . When we estimate the variance-covariance matrix of the moment conditions,  $S_0$ , we use the Newey and West (1987) method to adjust for heteroskedasticity and autocorrelations.

We also use the GMM procedure to test the null hypothesis,

$$H_0 : VR(1) = VR(2) = VR(3) = VR(4) = 1,$$

which yields the following moment conditions:

$$f_t(\theta_0) \equiv \begin{pmatrix} r_t^1 - \mu_1 \\ r_t^2 - \mu_2 \\ r_t^3 - \mu_3 \\ r_t^4 - \mu_4 \\ r_t^5 - \mu_5 \\ (r_t^1 - \mu_1)^2 - \sigma_5^2 \\ (r_t^2 - \mu_2)^2 - \sigma_5^2 \\ (r_t^3 - \mu_3)^2 - \sigma_5^2 \\ (r_t^4 - \mu_4)^2 - \sigma_5^2 \\ (r_t^5 - \mu_5)^2 - \sigma_5^2 \end{pmatrix},$$

and the moment restrictions

$$E[f_t(\theta_0)] = 0, \quad (8)$$

where  $\theta_0$  is the parameter vector,  $\theta_0 = (\mu_1, \mu_2, \mu_3, \mu_4, \mu_5, \sigma_5^2)'$ . Since the number of moment restrictions is 10 and the number of parameters is 6, this system is overidentified.

Testing the null hypothesis is equivalent to testing the overidentified restrictions. To test  $H_0$ , we first use GMM to estimate parameter vector  $\theta$  and save the final weighting matrix. Then, we use moment restrictions under the null along with the saved weighting matrix to re-estimate parameters and construct the following  $\chi^2$  statistic

$$\chi^2 = Tg_0'W_1g_0 - Tg_1'W_1g_1, \quad (9)$$

where subscript 0 denotes the restricted model and subscript 1 the unrestricted model. This is analogous to the likelihood ratio test. Note that the minimized value of  $g_1'W_1g_1$  from the unrestricted model is zero because Equation (7) is just identified. The degrees of freedom for the  $\chi^2$ -statistic equals the number of parameter restrictions.

### 3.4. An alternative test for individual stocks

Due to large number of firms in our sample and large number of moment restrictions required in the joint GMM test, the GMM approach is not tractable for studying individual stocks.<sup>12</sup> Therefore, we consider an alternative test which is based on cross-sectional median variance ratios.

<sup>12</sup>There are more than 2000 firms in our sample. For each firm, there are ten moment restrictions. A joint test of the equality of five variances for all firms will require more than 20,000 moment restrictions.

For the analysis of individual stocks, we first calculate the cross-sectional median of individual stocks' variance ratios in each year, and then, we treat these medians as independent time-series observations to perform the standard  $t$ -test. By using medians rather than means, we avoid the Jensen's inequality problem. Since we use one stock's variance ratio in a year, rather than averaging the variance ratios of all the stocks, cross-sectional dependence is not an issue. In addition, overlapping observations are not a problem because we do not use the standard  $F$ -test for testing variance equality. Another noteworthy point is that the distribution of sample medians is asymptotically normal regardless of the underlying distribution under fairly weak assumptions. Thus, each time-series observation can be treated as a normal variate, which justifies the use of a  $t$ -test.

#### 4. DATA

The primary data used in this study are daily closing returns of NYSE/AMEX size decile portfolios and all NYSE/AMEX stocks in the CRSP (Center for Research in Security Prices) file. The NYSE/AMEX sample covers 29 years for the period from 1963 through 1992 (except for 1968).<sup>13</sup> For the analysis of individual stocks, we drop a stock if it does not have a market capitalization decile ranking (assigned by CRSP) in a given year.<sup>14</sup> In addition, we analyze both opening and closing returns of the Dow Jones 65 index from 1963 to 1990 and S&P 500 index futures from 1983 to 1993. Results from the index futures may address concerns about the nonsynchronous trading problem.

We use the following procedure to calculate seven-day returns measured on each day of the week for each portfolio and each stock. In each year, we first examine daily prices for pairs of adjacent calendar weeks to screen "valid" pairs. We define a valid pair of weeks as one with all ten closing (or opening) prices available. That is, a pair of weeks is not valid if one of the daily prices is missing or if there is a holiday. For a valid pair of adjacent weeks, we calculate five seven-day returns (Monday-to-Monday, Tuesday-to-Tuesday, . . . , Friday-to-Friday) as depicted in Diagram 1. We then roll over to the next pair by dropping the first week of the pair and adding the week that follows the pair. Repeating this procedure, we generate five series of seven-day returns. For each of the five weekly return series, if the number of valid week pairs is less than 25 in the year, we exclude observations for the year.

<sup>13</sup>As documented by French and Roll (1986), the NYSE and AMEX were closed on Wednesdays during the second half of 1968. The year is excluded from our analyses. We also exclude October 1987 and October 1989 from all analyses because of unusual volatility during these two months.

<sup>14</sup>This criterion automatically excludes ADRs (See CRSP documentation).

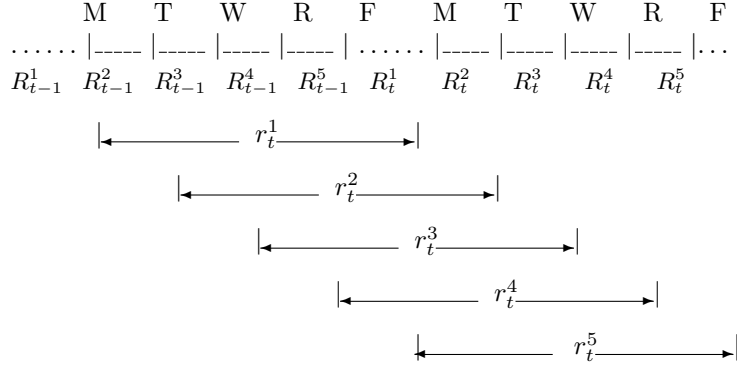
**Diagram 1. Weekly Return Calculation**

Notes:

- 1) M: Monday, T: Tuesday, W: Wednesday, R: Thursday, F: Friday.
- 2)  $R_t^1$ : daily return from Friday close to Monday close for week  $t$ ,  $\dots$ ,  $R_t^5$ : daily return from Thursday close to Friday close for week  $t$ .
- 3)  $r_t^1$ : weekly return from Monday close to Monday close,  $\dots$ ,  $r_t^5$ : weekly return from Friday close to Friday close.

It is important to note that we deliberately choose Monday as the starting day of each ten-day block. This design guarantees that the day immediately prior to any trading day other than two Mondays in the ten-day block is also a trading day. Similarly, the day immediately following any day which does not fall on Friday is also a trading day. Thus, we minimize the influence of holiday nontrading on weekly returns other than Monday-to-Monday or Friday-to-Friday returns. On the other hand, holidays on Mondays or Fridays extend weekend nontrading periods. A holiday on the Friday immediately prior to the ten-day block extends the preceding nontrading period from two to three days. Monday holidays immediately following the ten-day block extend the following nontrading period. These extended nontrading periods are likely to accentuate the patterns predicted by our hypotheses.

## 5. EMPIRICAL RESULTS

### 5.1. The NYSE/AMEX Portfolios

In this section, we analyze returns of NYSE/AMEX size decile portfolios as well as value- and equal-weighted market portfolios. In particular, we examine variance ratios VR(1), VR(2), VR(3) and VR(4) to evaluate the relative importance of transitory volatility on each day of the week. The size decile portfolio returns are equal-weighted. Daily returns for these portfolios are obtained from the CRSP file and include dividends.

We analyze portfolio returns for two reasons. First, various firm-specific frictions are likely to be diversified away in portfolios. Thus, the analysis of portfolio returns enables us to assess the relative magnitudes of portfolio-wide transitory volatility. For example, discreteness of price movements inflates the estimated variances of individual stock returns and is likely to pull the estimated variance ratios toward one. Portfolio returns are not likely to be subject to such a problem. Second, numerous previous studies use weekly portfolio returns measured on an arbitrarily chosen weekday, without considering systematic differences in variances of weekly returns across days of the week. Since these studies typically use the second moment for primary or inferential purposes, the equality of weekly return variances across days of the week is a relevant issue.

**TABLE 1.**

GMM Estimates of Variance Ratios of Weekly Returns for NYSE/AMEX Portfolios for the Period January 1963 - December 1992

Size	VR(1) <sup>a</sup> (s.e.)	VR(2) (s.e.)	VR(3) (s.e.)	VR(4) (s.e.)	$\chi_{(4)}^2 - \text{stat}^b$ [p-value]
Smallest	1.243** (0.095)	1.232** (0.104)	1.088* (0.059)	1.073** (0.038)	11.0 [0.026]
2	1.254** (0.108)	1.190** (0.113)	1.051 (0.066)	1.035 (0.042)	9.9 [0.041]
3	1.288** (0.111)	1.230** (0.115)	1.084 (0.066)	1.051 (0.044)	10.9 [0.027]
4	1.291** (0.105)	1.239** (0.112)	1.085* (0.064)	1.057 (0.045)	12.4 [0.015]
5	1.252** (0.101)	1.181** (0.101)	1.046 (0.060)	1.048 (0.045)	12.8 [0.012]
6	1.297** (0.102)	1.222** (0.104)	1.077* (0.062)	1.072* (0.047)	16.8 [0.002]
7	1.261** (0.093)	1.166** (0.092)	1.062 (0.056)	1.052 (0.042)	16.4 [0.003]
8	1.257** (0.087)	1.152** (0.083)	1.059 (0.054)	1.061* (0.042)	17.8 [0.001]
9	1.272** (0.085)	1.153** (0.079)	1.061 (0.056)	1.053* (0.040)	18.7 [0.001]
Largest	1.237** (0.088)	1.074 (0.084)	1.006 (0.064)	1.024 (0.040)	18.8 [0.001]
EW	1.279** (0.101)	1.206** (0.108)	1.065 (0.061)	1.060* (0.043)	16.6 [0.002]
VW	1.262** (0.088)	1.128* (0.085)	1.038 (0.062)	1.040 (0.042)	18.3 [0.001]

<sup>a</sup> VR(i) is the ratio of day i-to-day i return variance relative to Friday-to-Friday return variance (i=1,Monday; i=2, Tuesday; i=3, Wednesday; i=4, Thursday). The corresponding asymptotic standard error is in parenthesis.

<sup>b</sup> The  $\chi^2_{(4)}$  statistic is for testing the equality of five variances of weekly returns, i.e.,  $H_0 : VR(1) = VR(2) = VR(3) = VR(4) = 1$ .

\*\* and \* indicate the variance ratio is significantly greater than one at the 5% and 10% levels, respectively, in a one-tail Z-test.

Table 1 presents the GMM estimates of variance ratios and their asymptotic standard errors. The reported standard errors are based on the estimated covariance matrix of parameters. The Newey and West (1987) adjustment with ten lags is used to obtain a heteroskedasticity and autocorrelation consistent covariance matrix. The last column shows  $\chi^2_{(4)}$  values generated from a GMM system under the null hypothesis

$$H_0 : VR(1) = VR(2) = VR(3) = VR(4) = 1.$$

For the equal-weighted and value-weighted portfolios, Monday-to-Monday return variances are significantly greater than that of Friday-to-Friday return variances at the 1% significance level. For the equal-weighted portfolio, Monday-to-Monday return variance is 27.9% ( $Z$ -stat = 2.8) more volatile than Friday-to-Friday return variance. For the value-weighted portfolio, the difference is 26.2% ( $Z$ -stat = 3.0). In addition, the variance ratio declines monotonically towards one as trading proceeds during the week. For example, the estimates of four variance ratios (standard errors), VR(1), VR(2), VR(3) and VR(4), are 1.279 (0.101), 1.206 (0.108), 1.065 (0.061) and 1.060 (0.043) for the equal-weighted portfolio, and 1.262 (0.088), 1.128 (0.085), 1.038 (0.062) and 1.040 (0.042) for the value-weighted portfolio. The variance of Tuesday-to-Tuesday returns is still significantly greater than that of Friday-to-Friday returns, although the difference between the two variances is smaller than that between Monday-to-Monday and Friday-to-Friday return variances. The observed pattern of steadily declining variances is consistent with implications of price formation models.

Table 1 also reports estimated variance ratios for each size decile portfolio. Similar to the result for the equal-weighted and value-weighted portfolios, seven-day return variances steadily decline for all size decile portfolios. Variances of Monday-to-Monday and Tuesday-to-Tuesday returns are higher than that of Friday-to-Friday returns at the 5% significance level (the largest decile portfolio is the exception). The difference between Wednesday-to-Wednesday (or Thursday-to-Thursday) return variance and Friday-to-Friday return variance is small. The evidence suggests that the pattern of steadily declining variances over the week is robust across all size decile portfolios.

The  $\chi^2$  values reported in Table 1 are significant for all portfolios at the 5% level, indicating that the equality of all variances is strongly rejected. Generally, the significance level increases as firm size increases.

## 5.2. Individual stocks

We have documented that transitory volatility differs significantly across days of the week and steadily declines over the week for various portfolios. In this section, we analyze NYSE/AMEX individual stocks and examine transitory volatility at the firm level.

**TABLE 2.**  
Summary Statistics of Variance Ratios of Weekly Returns for NYSE/AMEX  
Individual Stocks during the Period January 1963 - December 1992

Size	VR(1) <sup>a</sup> (s.e.)	VR(2) (s.e.)	VR(3) (s.e.)	VR(4) (s.e.)
Smallest	1.038** (0.008)	1.043** (0.012)	1.011* (0.007)	1.013** (0.006)
2	1.047** (0.010)	1.037** (0.015)	1.018** (0.010)	1.016** (0.007)
3	1.048** (0.009)	1.035** (0.013)	1.005 (0.009)	1.007 (0.007)
4	1.055** (0.012)	1.053** (0.018)	1.025** (0.011)	1.019** (0.009)
5	1.064** (0.011)	1.047** (0.016)	1.021** (0.009)	1.013* (0.008)
6	1.070** (0.012)	1.053** (0.016)	1.022** (0.013)	1.013* (0.009)
7	1.071** (0.012)	1.051** (0.017)	1.021** (0.012)	1.007 (0.008)
8	1.088** (0.015)	1.059** (0.019)	1.026** (0.011)	1.013** (0.008)
9	1.090** (0.019)	1.055** (0.021)	1.018* (0.012)	1.016** (0.008)
Largest	1.102** (0.030)	1.053** (0.026)	1.016 (0.015)	1.001 (0.011)
All	1.061** (0.005)	1.039** (0.006)	1.015** (0.003)	1.011** (0.003)

<sup>a</sup> VR(i) is the ratio of day i-to-day i return variance relative to Friday-to-Friday return variance (i=1, Monday; i=2, Tuesday; i=3, Wednesday; i=4, Thursday). We calculate four variance ratios of weekly returns for each stock in each year, and get the median variance ratios across all stocks in each year. Then we obtain the mean of annual variance ratios across the sample period (observations in 1968



are excluded). The standard error is calculated based on annual median variance ratios and is given in the parenthesis.

\*\* and \* indicate the variance ratio is significantly greater than one at the 5% and 10% levels, respectively, in a one-tail t-test.

For each stock in the sample, we calculate five variances of seven-day returns and four variance ratios, VR(1), VR(2), VR(3) and VR(4). In each year, we compute the cross-sectional median of individual variance ratios. For the NYSE/AMEX sample, we obtain four sets of 29 median variance ratios over the sample period from 1963 to 1992, giving us 29 median variance ratios for each day of the week.

Table 2 gives summary statistics of median variance ratios for NYSE/AMEX stocks. For the entire sample, Monday-to-Monday return variances are 6.1% greater on average than Friday-to-Friday return variances, and the variance ratio of Monday-to-Monday returns relative to Friday-to-Friday returns deviates from one significantly ( $t$ -value = 12.2). Furthermore, the variance ratio decreases gradually over the week. Averages (standard errors) of the four variance ratios, VR(1), VR(2), VR(3) and VR(4), are 1.061 (0.005), 1.039 (0.006), 1.015 (0.003) and 1.011 (0.003), respectively. The variance of Tuesday-to-Tuesday returns is still significantly greater than that of Friday-to-Friday returns, although the difference is small (3.9%). The observed pattern of steadily declining variance ratios is consistent with implications of price formation models.

In Table 2, we also report summary statistics of median variance ratios for NYSE/AMEX stocks in each size decile. Two systematic patterns emerge. First, seven-day return variances steadily decline for all market capitalization groups with a few minor exceptions. Thus, we conclude that the pattern of steadily declining variances is robust across all market capitalizations. Second, there is a systematic cross-sectional variation in VR(1), the variance ratio of Monday-to-Monday returns relative to Friday-to-Friday returns. VR(1) increases monotonically with the size of the firm. The other three variance ratios VR(2), VR(3) and VR(4) do not exhibit such a monotonic cross-sectional pattern. Consequently, decreases in seven-day variances from Monday through Friday are much greater and faster for large firms than for small firms. For example, for stocks in the largest decile, the variance of Monday-to-Monday returns is greater on average than that of Friday-to-Friday returns by 10.2%. About one half of the excess volatility in Monday prices disappears on Tuesdays, and it becomes statistically insignificant on Wednesdays. In contrast, for stocks in the smallest decile, the variance of Monday-to-Monday returns is greater than that of Friday-to-Friday returns by a small margin of only 3.8%. The variance of Tuesday-to-Tuesday returns is still as high as that of Monday-to-Monday returns. Transitory volatility declines starting from

Wednesdays. Since the firm size is highly correlated with the trading frequency, we interpret these cross-sectional patterns as being consistent with price formation models.

### 5.3. Comparisons

Why do portfolios exhibit a much stronger declining pattern in transitory volatility than individual stocks? A plausible explanation is that stock prices contain idiosyncratic noise which is constant throughout days of the week. Examples of such noise are those due to price discreteness and the response of monopolistic specialists. When a portfolio is formed, this noise is diversified away. If diversification reduces the variance by the same amount across all days of the week, it will raise the variance ratio of portfolios. Similar to our results at the weekly level, Gerety and Mulherin (1994) find that, for the Dow Jones 65 index, the variance ratio of open-to-open returns relative to close-to-close returns is significantly greater than the average variance ratio of individual firms (1.30 vs. 1.12). In Appendix A, we provide an illustrative example to show that, under fairly weak assumptions, the variance ratio of individual stocks is smaller than that of the portfolio.

## 6. FURTHER ANALYSIS

In this section, we address various concerns regarding our design and assess whether our results are applicable to other markets by examining a long time-series of the Dow Jones Index, the S&P 500 index futures, and the Japanese Nikkei 225 Index.

### 6.1. Evidence from a long time series: 1897-1990

This subsection presents supplementary evidence from the Dow Jones Index for the period from 1897 through 1990.<sup>15</sup> While this data set enables us to extend the sample period substantially, it has a drawback: it does not include dividends. The omitted dividends may bias the results if ex-dividend days are distributed unevenly across days of the week.<sup>16</sup>

---

<sup>15</sup>This series is a merged version of four different data sets: Dow Jones 12 Industrials (January 1897 – July 1914), Dow Jones 20 Industrials (December 1914 – December 1928), Dow Jones 30 Industrials (January 1929 – May 1938) and Dow Jones 65 Composite (June 1938 – December 1990). Excluded from the analysis are years 1914 and 1938 for series switching and year 1968 for frequent exchange closings. The Great Depression of 1929–1934, the Crash of October 1987 and October 1989 are also excluded from the analysis. Weekly returns are calculated within each data set. We would like to thank Harold Mulherin for providing us with the Dow Jones index data.

<sup>16</sup>However, Kim and Park (1994) suggest that the effect of the omitted dividend on index returns may be very small.

**TABLE 3.**

GMM Estimates of Variance Ratios of Weekly Returns for the Dow Jones Index (1897-1990) and the S&P 500 Index Futures (1983-1993)

	VR(1) <sup>b</sup> (s.e.)	VR(2) (s.e.)	VR(3) (s.e.)	VR(4) (s.e.)	$\chi^2_{(4)} - \text{stat}^c$ [p-value]
Dow Jones Index	1.166** (0.052)	1.063* (0.044)	1.016 (0.038)	1.033 (0.033)	17.4 [0.002]
S&P 500 Index Futures	1.249** (0.126)	1.185* (0.113)	1.102 (0.101)	1.076 (0.074)	5.5 [0.244]

<sup>a</sup> Four different data sets are merged into a single one: DJ 12 (1/2/1897 - 7/30/1914), DJ 20 (12/12/1914 - 12/31/1928), DJ 30 (1/2/1929 - 6/1/1938) and DJ 65 (6/2/1938 - 12/31/1990). Excluded from this analysis are years 1914 and 1938 for series switching and year 1968 for frequent exchange closings. The Great Depression of 1929-1934, the Crash of October, 1987 and October, 1989 are also excluded from the analysis.

<sup>b</sup> VR(i) is the ratio of day i-to-day i return variance relative to Friday-to-Friday return variance (i=1, Monday; i=2, Tuesday; i=3, Wednesday; i=4, Thursday). The corresponding asymptotic standard error is in parenthesis.

<sup>c</sup> The  $\chi^2_{(4)}$  statistic is for testing the equality of five variances of weekly returns, i.e.,  $H_0 : VR(1) = VR(2) = VR(3) = VR(4) = 1$ .

\*\* and \* indicate the variance ratio is significantly greater than one at the 5% and 10% levels, respectively, in a one-tail Z-test.

As before, we estimate variance ratios of weekly returns by using the GMM approach.<sup>17</sup> The GMM estimates of four variance ratios are reported in Table 3. For the period of 1897–1990, the estimated variance ratios VR(1), VR(2), V(3) and VR(4), are 1.166, 1.063, 1.016 and 1.033, respectively. Again, the  $\chi^2$  test strongly rejects the equality of five variances. The magnitude of point estimates are generally similar to those for the largest portfolio, except VR(1) which is about 6% lower than that for the largest portfolio. Thus, the evidence suggests that the uncovered pattern in transitory volatility for the CRSP portfolios has existed in the Dow Jones index for a long time.

## 6.2. Nonsynchronous trading and evidence from S&P 500 index futures

Previous sections show that transitory volatility steadily declines across days of the week for various well-diversified portfolios, including the value-

<sup>17</sup>The New York Stock Exchange was open for two hours on Saturdays prior to September 29, 1952, except for the Summer months of 1945–1952 during which there were no Saturday tradings. We ignore Saturday trading because we do not have complete data on Saturdays. This may bias the results, but the direction of the bias is against finding the pattern that we are seeking. Saturday trading lessens the weekend nontrading period.

and equal-weighted market portfolios, and the Dow Jones index. This subsection examines the S&P 500 index futures data to address two important questions that arise from the use of portfolios. First, since all stocks do not close at the same time, the portfolio return is subject to the nonsynchronous trading problem. By contrast, the S&P 500 index futures is a single security, and it is not subject to the nonsynchronous trading problem. Second, if the observed pattern for portfolios is truly due to the price formation process that involves market-wide factors, this should be reflected in securities that have market risk only.

We examine the S&P 500 index futures for the period 1983–1993. To construct a single daily return series from futures contracts with various maturities, we use a standard procedure. For liquidity reasons, we use the nearest contract price if the contract has more than 15 days to maturity, and then, roll over to the next nearest contract. Based on the constructed single daily return series, we calculate five-day (close-to-close) return variances using the procedure described in Section 3<sup>18</sup>

In Table 3, we report GMM estimates of variance ratios of weekly returns. For the S&P 500 index futures. Monday-to-Monday return variance is 24.9% more volatile than Friday-to-Friday return variance, and Tuesday-to-Tuesday return variance is 18.5% more volatile. By Wednesdays, transitory volatility due to weekend nontrading is fully dissipated, and it is indistinguishable from that on Fridays. The point estimates of variance ratios are comparable to those for large decile portfolios reported in Table 1. The evidence from the index futures is consistent with that from the NYSE/AMEX portfolios. The similar declining pattern observed in both portfolios and index futures suggests that the pattern is not likely to be driven by nonsynchronous trading. Further, the significant difference in transitory volatility across days of the week is in part due to the market-wide price formation process.

### 6.3. Sensitivity to the choice of sample period

We examine the sensitivity of the results to the choice of sample period. This investigation is potentially important because trading techniques and investors' knowledge of the market may have evolved over time.

---

<sup>18</sup>All daily returns within each ten-day block are drawn from the same contract.

**TABLE 4.**

Variance Ratios of Weekly Returns for NYSE/AMEX Portfolios, Dow Jones Index and Individual Stocks – Subperiod Results

A. GMM Estimates of Variance Ratios for NYSE/AMEX Portfolios						
Period		VR(1) <sup>a</sup> (s.e.)	VR(2) (s.e.)	VR(3) (s.e.)	VR(4) (s.e.)	$\chi^2_{(4)} - \text{stat}^b$ [p-value]
1963-1977	EW	1.359** (0.156)	1.306** (0.176)	1.096 (0.097)	1.055 (0.053)	11.6 [0.020]
	VW	1.270** (0.143)	1.141 (0.149)	1.005 (0.100)	1.042 (0.060)	12.1 [0.016]
1978-1992	EW	1.191* (0.124)	1.095 (0.110)	1.031 (0.072)	1.066 (0.071)	6.4 [0.171]
	VW	1.255** (0.109)	1.117* (0.090)	1.070 (0.076)	1.040 (0.061)	7.9 [0.095]

B. GMM Estimates of Variance Ratios for the Dow Jones Index <sup>c</sup>						
Period		VR(1) (s.e.)	VR(2) (s.e.)	VR(3) (s.e.)	VR(4) (s.e.)	$\chi^2_{(4)} - \text{stat}$ [p-value]
1897 - 1945		1.135** (0.072)	1.044 (0.061)	1.035 (0.055)	1.033 (0.049)	5.4 [0.249]
1946 - 1962		1.276** (0.111)	1.129* (0.094)	0.967 (0.081)	1.052 (0.058)	12.3 [0.015]
1963 - 1990		1.198** (0.084)	1.085 (0.079)	0.998 (0.057)	1.028 (0.042)	13.6 [0.009]
1946 - 1990		1.216** (0.067)	1.095* (0.062)	0.987 (0.046)	1.033 (0.034)	23.6 [0.000]

C. Average Variance Ratios for All Individual Stocks<sup>d</sup>

Period	VR(1) (s.e.)	VR(2) (s.e.)	VR(3) (s.e.)	VR(4) (s.e.)
1963-1977	1.075** (0.005)	1.057** (0.007)	1.021** (0.005)	1.012** (0.003)
1978-1992	1.060** (0.008)	1.041** (0.009)	1.016** (0.005)	1.012** (0.004)

<sup>a</sup> VR(i) is the ratio of day i-to-day i return variance relative to Friday-to-Friday return variance (i=1, Monday; i=2, Tuesday; i=3, Wednesday; i=4, Thursday). The corresponding asymptotic standard error is in parenthesis.

<sup>b</sup> The  $\chi^2_{(4)}$  statistic is for testing the equality of five variances of weekly returns, i.e.,  $H_0 : VR(1) = VR(2) = VR(3) = VR(4) = 1$ .

<sup>c</sup> Four different data sets are merged into a single one: DJ 12 (1/2/1897 - 7/30/1914), DJ 20 (12/12/1914 - 12/31/1928), DJ 30 (1/2/1929 - 6/1/1938) and

DJ 65 (6/2/1938 - 12/31/1990). Excluded from this analysis are years 1914 and 1938 for series switching and year 1968 for frequent exchange closings. The Great Depression of 1929-1934, the Crash of October, 1987 and October, 1989 are also excluded from the analysis.

<sup>d</sup> We calculate four variance ratios of weekly returns for each stock in each year, and get the median variance ratios across all stocks in each year. Then we obtain the mean of annual variance ratios in each subperiod. The standard error is calculated based on annual median variance ratios in the subperiod and is given in the parenthesis.

\*\* and \* indicate the variance ratio is significantly greater than one at the 5% and 10% levels, respectively, in a one-tail Z-test (Panel A and Panel B) or in a one-tail t-test (Panel C).

Panel A of Table 4 reports the results for two equally divided subperiods, 1963-1977 and 1978-1992 for the equal- and value-weighted portfolios. Panel B is for the Dow Jones index for four subperiods: 1897-1945, 1946-1962, 1963-1990 and 1946-1990. Panel C is for all individual stocks for two subperiods: 1963-1977 and 1978-1992.<sup>19</sup> The table indicates the patterns are not materially different among subperiods. Thus, we conclude that the observed patterns are robust to the choice of sample period.

As a final check, we examine the time series behavior of annual cross-sectional medians of variance ratios across days of the week for all NYSE/AMEX stocks. For most of the 29 years of the sample period, seven-day return variances steadily decline over the week. For example, variances of Monday-to-Monday returns are greater than those of Tuesday-to-Tuesday returns for 24 years (binomial  $Z$ -stat = 3.5), and are greater than those of Friday-to-Friday returns for 26 years ( $Z$ -stat = 4.3). Variances of Thursday-to-Thursday returns are greater than those of Friday-to-Friday returns for 21 years ( $Z$ -stat = 2.4).

#### 6.4. Thin trading

A concern may arise from the possibility of thin trading (including non-trading). The observed steadily declining pattern of variance ratios may be attributable to thin trading for some stocks rather than the slow dissipation of transitory volatility. Thus, we repeat the exercise for stocks in the Dow Jones Industrial Average. Since these stocks are actively traded, they are unlikely to suffer from the thin trading problem. Three of thirty Dow Jones stocks, as of December 1991, are eliminated because of non-availability of a complete price history for the years from 1963 to 1992.

The pattern of seven-day return variances is very similar to the NYSE/AMEX stocks in the largest size decile. The average (standard error) of median

<sup>19</sup>The three panels correspond to Tables 1, 2 and 3, respectively. To maintain the compatibility with these tables, we employ the same procedure.

variance ratios over the sample period is 1.146 (0.054), 1.061 (0.029), 1.026 (0.020) and 1.009 (0.014) for each of the first four days of the week, respectively.

### 6.5. Holidays

The arguments we made to develop our hypotheses should apply to non-trading on holidays as well. However, it is difficult to distinguish the impact of holidays on variance ratios from that of weekend nontrading for two reasons: (i) in our 29-year sample period, the majority of holidays fall on Mondays (43%) or Fridays (23%). Since holidays falling on Mondays or Fridays extend the weekend nontrading period, it is difficult to distinguish between these holidays and weekends, and (ii) in the sample period, the number of holidays falling on Tuesday, Wednesday or Thursday is only 82; that is, approximately 2.8 per year. Unless we calculate variance ratios based on time-series spanning many years, we are not likely to obtain meaningful estimates. However, variance ratios based on long time-series data are likely to be determined by a few high variance years. Therefore, we do not attempt to directly isolate the impact of holidays.

Instead, we examine the pattern of variance ratios with Tuesday as the starting day of each ten-day block. Starting from Tuesdays allows the Mondays that precede the ten-day block to be holidays. In this case, three nontrading days precede the first Tuesday in the block, which will elevate the variance of Tuesday-to-Tuesday returns. The elevation of the variance may be nontrivial because approximately 3.6 Mondays per year are holidays. The variance of Wednesday-to-Wednesday may also be elevated to a less degree. Each of the two Mondays in the ten-day block should follow exactly two nontrading days (weekends), since this altered design does not allow holidays on Fridays. Thus, we expect the variance of Monday-to-Monday returns to be lower than that obtained from the original design. Since the pattern in variance ratios is most distinct for large stocks, we experiment using the NYSE/AMEX stocks in the largest decile. Indeed, variance ratios on Tuesdays and Wednesdays are slightly greater than those obtained previously. However, the steadily declining pattern in transitory volatility over the week remain unchanged. The mean of 29 cross-sectional median variance ratios obtained is 1.107, 1.089, 1.049 and 1.022 for each of the first four days of the week, respectively. In brief, changing the starting day of each ten-day block does not affect our results materially.

### 6.6. Evidence from opening prices

This section examines the sensitivity of our results to the choice of price measurement time. While we have used daily closing prices so far, some may argue that using opening prices is more consistent with the spirit of price formation models. The reason is that the impact of weekend non-

trading on prices should be the greatest at the opening on Mondays. Since reliable opening prices for the NYSE/AMEX stocks do not exist over a long time period,<sup>20</sup> we focus our analysis on the Dow Jones 65 Index for which the opening prices are available in the financial press over an extensive sample period (1963–1990). In addition, we examine opening prices of the S&P 500 index futures from 1983 to 1993.

Stoll and Whaley (1990) document that, for large NYSE stocks, the time delay between the first transaction and the market opening is about six minutes. Consequently, the reported opening index price may suffer from the “stale quote” or the nonsynchronous trading problem, which may induce biases in the variance estimates.<sup>21</sup> The nonsynchronous trading problem is generally more serious at the open than at the close. To mitigate the problem, we consider two measures of opening prices. The first measure is the quoted opening price recorded when the NYSE opens, and the second is the price quoted one hour after the NYSE opens.<sup>22</sup>

Table 5 reports GMM estimates of variance ratios of weekly returns for the Dow Jones 65 index and S&P 500 index futures. For the Dow Jones 65 index, by using the first quoted price as the opening price, the four variance ratios (standard errors), VR(1), VR(2), VR(3) and VR(4), are 1.129 (0.075), 1.165 (0.081), 1.054 (0.069) and 1.012 (0.044), respectively. When using the price recorded one hour after the official exchange opening, the four variance ratios (standard errors) are 1.173 (0.079), 1.159 (0.077), 1.049 (0.063) and 1.042 (0.042). Both Monday-to-Monday and Tuesday-to-Tuesday return variances are significantly greater than Friday-to-Friday return variance at the 5% significance level. For both definitions of the opening price, transitory volatility in opening prices declines gradually over the week, but does not remain constant. For S&P 500 index futures, the four variance ratios are 1.150, 1.159, 1.153 and 1.043, and transitory volatility declines substantially by Thursday morning. Collectively, the evidence is consistent with the price formation models and suggests that weekend nontrading has more impact on the following day’s opening price than the overnight nontrading period.

---

<sup>20</sup>The ISSM database contains opening prices for the NYSE/AMEX stocks over the period from 1983 to 1992. However, there are many missing observations for the period between 1983 and 1987.

<sup>21</sup>The opening price of the Dow Jones index is calculated as follows: if a stock opens with a delay, its previous day’s closing price is used to calculate the index level.

<sup>22</sup>To address the same problem, Lin, Engle and Ito (1994) use a price index quoted 30 minutes after the NYSE officially opens. They find that “the stock price index at 9:30 on the NYSE contains stale quotes” and that “the index at the official opening time may not be suitable for measuring the opening quotes of the day”, p520.



**TABLE 5.**  
GMM Estimates of Variance Ratios of Weekly Returns for the Dow Jones  
Index (1963-1990) and the S&P 500 Index Futures (1983-1993)  
Using Opening Prices

	VR(1) <sup>a</sup>	VR(2)	VR(3)	VR(4)	$\chi^2_{(4)} - \text{stat}^b$
	(s.e.)	(s.e.)	(s.e.)	(s.e.)	[p-value]
Dow Jones 65 Index (opening price)	1.129** (0.075)	1.165** (0.081)	1.054 (0.069)	1.012 (0.044)	8.1 [0.089]
Dow Jones 65 Index (1st. hour price)	1.173** (0.079)	1.159** (0.077)	1.049 (0.063)	1.042 (0.042)	9.49 [0.050]
S&P 500 Futures (opening price)	1.150* (0.106)	1.159* (0.121)	1.153* (0.098)	1.043 (0.099)	3.0 [0.552]

<sup>a</sup> VR(i) is the ratio of day i-to-day i return variance relative to Friday-to-Friday return variance (i=1,Monday; i=2, Tuesday; i=3, Wednesday; i=4, Thursday). The corresponding asymptotic standard error is in parenthesis.

<sup>b</sup> The  $\chi^2_{(4)}$  statistic is for testing the equality of five variances of weekly returns, i.e.,  $H_0 : VR(1) = VR(2) = VR(3) = VR(4) = 1$ .

\*\* and \* indicate the variance ratio is significantly greater than one at the 5% and 10% levels, respectively, in a one-tail Z-test.

### 6.7. Evidence from the Japanese Nikkei 225 Daily Index

In this subsection, we investigate whether our results are unique to U.S. stock markets. For this purpose, we analyze the Nikkei 225 Index for the period from 1973 to 1992.<sup>23</sup> The Nikkei Index like the Dow Jones Index does not include dividends.

Table 6 reports the GMM estimates of variance ratios.<sup>24</sup> To assess the robustness of the results, we repeat the experiment for two equally divided subperiods.

In general, the results are similar to those obtained for the U.S. market. For example, the GMM estimates (standard errors) of VR(1), VR(2), VR(3) and VR(4) are 1.368 (0.145), 1.209 (0.115), 1.199 (0.097) and 1.195 (0.088), respectively, for the sample period 1973-1992. The evidence from the Japanese stock market raises the possibility that our findings may hold at a more universal level.

<sup>23</sup>The closing prices for the period prior to July 1987 are obtained from Jinwoo Park. The rest of the data are manually collected from the *Financial Times*.

<sup>24</sup>The Tokyo Stock Exchange was open on Saturdays prior to 1973. For the period from January 1973 to January 1989, the Exchange was open on some Saturdays. Since the inclusion of Saturdays increases the complexity of the analysis without adding much, we ignore Saturday trading.

**TABLE 6.**

GMM Estimates of Variance Ratios of Weekly Returns for the Nikkei 225 Index for the Period January 1973 – December 1992

Period	VR(1) <sup>b</sup> (s.e.)	VR(2) (s.e.)	VR(3) (s.e.)	VR(4) (s.e.)	$\chi^2_{(4)}$ – stat <sup>c</sup> [p-value]
1973 - 1992	1.368** (0.145)	1.209** (0.115)	1.199** (0.097)	1.195** (0.088)	10.5 [0.032]
1973 - 1982	1.210* (0.162)	1.045 (0.125)	0.995 (0.116)	0.955 (0.081)	4.2 [0.375]
1983 - 1992	1.472** (0.221)	1.315** (0.176)	1.329** (0.145)	1.347** (0.128)	10.3 [0.036]

<sup>a</sup> VR(i) is the ratio of day i-to-day i return variance relative to Friday-to-Friday return variance (i=1,Monday; i=2, Tuesday; i=3, Wednesday; i=4, Thursday). The corresponding asymptotic standard error is in parenthesis.

<sup>b</sup> The  $\chi^2_{(4)}$  statistic is for testing the equality of five variances of weekly returns, i.e.,  $H_0 : VR(1) = VR(2) = VR(3) = VR(4) = 1$ .

\*\* and \* indicate the variance ratio is significantly greater than one at the 5% and 10% levels, respectively, in a one-tail Z-test.

### 6.8. Discussions

We find that prices on Mondays contain significantly greater transitory volatility than prices on the other days of the week, and that transitory volatility declines steadily over the week. Our findings are consistent more with models of price formation than with the exogenous liquidity demand model, since the latter model predicts a U-shaped weekly pattern of transitory volatility. Another noteworthy point is that our tests indicate the importance of market-wide factors in the price formation process. Our results on portfolios suggest that much of the firm-level transitory volatility does not appear to be diversifiable. If all transitory volatility at the firm level can be diversified, the variance ratios of portfolio returns should be one. We view that the evidence is consistent with the results in Barclay, Litzenberger and Warner (1990), who find that “private information revealed through trading has market-wide, industry, and firm-specific components.”<sup>25</sup>

## 7. CONCLUSION

In this study, we examine the evolving pattern of transitory volatility over the week. Our test centers on comparisons of seven-day return variances measured on different days of the week. This technique keeps the flow

<sup>25</sup>See Barclay, Litzenberger and Warner (1990), p.245.

of information constant over the week and differs from those used in the existing studies of daily return variances.

The results are generally consistent with the implications of price formation models. We find, for both portfolios and individual stocks, transitory volatility steadily declines throughout the week. This pattern is much stronger for portfolios as a result of the diversification effect of firm-specific frictions. Stocks of larger firms exhibit a faster decline than those of smaller firms.

Several important conclusions can be drawn from our results. First, it takes more time than previously thought for prices to incorporate private information. Second, seasonal variation in transitory volatility contained in individual stock prices is mainly induced by the process of price formation rather than by exogenous liquidity demand. Third, much of transitory volatility arising from the process of price formation does not appear diversifiable. Fourth, researchers who use weekly returns and, especially those who are concerned with the second moments of weekly returns, should be careful in defining the week. Not all weekdays are the same.

## APPENDIX A

This appendix presents a plausible example in which the variance ratio of an equal-weighted portfolio is greater than that of the component stocks.

In Section 3.1, the observed seven-day return for firm  $i$  on day  $k$  is given by

$$r_{it}^k = \nu_{it}^{*k} + \beta_i r_{mt}^{*k} + \beta_i (\epsilon_{mt}^k - \epsilon_{m,t-1}^k) + (\epsilon_{it}^k - \epsilon_{i,t-1}^k), \quad (\text{A1})$$

and the equal-weighted portfolio return of  $n$  stocks is

$$r_{mt}^k = r_{mt}^{*k} + \epsilon_{mt}^k - \epsilon_{m,t-1}^k.$$

We make two assumptions: (i) the variance ratios of the equal-weighted portfolio (VR(1), VR(2), VR(3) and VR(4)) are greater than one, i.e.,  $\frac{\text{Var}(r_{mt}^k)}{\text{Var}(r_{mt}^{*k})} > 1$ ,  $k = 1, 2, 3$ , or 4; and (ii) the variances of firm-specific frictions are the same across days of the week, i.e.,  $\text{Var}(\epsilon_{it}^k - \epsilon_{i,t-1}^k) = \text{Var}(\epsilon_{it}^5 - \epsilon_{i,t-1}^5)$ ,  $k = 1, 2, 3$ , or 4. Both assumptions are reasonable. The first one is supported by the evidence reported in Table 1. For the second assumption, since firm-specific frictions are primarily due to price discreteness and the response of monopolistic specialists, there is no conceivable reason to believe their variances change from one day to another day.

For simplicity, we assume all covariance terms are zero in the following discussion (the proof is similar and the result still holds when the covariance

terms are non-zeros). The variance ratio,  $VR(k)$ , for firm  $i$  is given by

$$\frac{Var(r_{it}^k)}{Var(r_{it}^5)} = \frac{Var(\nu_{it}^{*k}) + \beta_i^2 Var(r_{mt}^{*k}) + \beta_i^2 Var(\epsilon_{mt}^k - \epsilon_{m,t-1}^k) + Var(\epsilon_{it}^k - \epsilon_{i,t-1}^k)}{Var(\nu_{it}^{*5}) + \beta_i^2 Var(r_{mt}^{*5}) + \beta_i^2 Var(\epsilon_{mt}^5 - \epsilon_{m,t-1}^5) + Var(\epsilon_{it}^5 - \epsilon_{i,t-1}^5)}$$

Since the variance of firm-specific true return of day  $k$ -to-day  $k$  is the same as that of Friday-to-Friday, we have  $Var(\nu_{it}^{*k}) = Var(\nu_{it}^{*5})$ . Using the result  $\frac{A+C}{B+C} < \frac{A}{B}$  when  $\frac{A}{B} > 1$ , we have

$$\frac{Var(r_{it}^k)}{Var(r_{it}^5)} < \frac{\beta_i^2 Var(r_{mt}^{*k}) + \beta_i^2 Var(\epsilon_{mt}^k - \epsilon_{m,t-1}^k)}{\beta_i^2 Var(r_{mt}^{*5}) + \beta_i^2 Var(\epsilon_{mt}^5 - \epsilon_{m,t-1}^5)} = \frac{Var(r_{mt}^k)}{Var(r_{mt}^5)}$$

Thus, the variance ratio of a component stock is smaller than that of the equal-weighted portfolio.

## REFERENCES

- Amihud, Y. and H. Mendelson, 1987, Trading mechanisms and stock returns: An empirical investigation. *Journal of Finance* **42**, 533-553.
- , 1991, Volatility, efficiency and trading: evidence from the Japanese stock market. *Journal of Finance* **46**, 1765-1791.
- Bagehot, W., 1971, The only game in town. *Financial Analysts Journal* **27**, 12-14.
- Barclay, M.J., R.H. Litzenberger, and J. B. Warner, 1990, Private information, trading volume and stock-return variances. *Review of Financial Studies* **3**, 233-253.
- Blume, L., D. Easley, and M. O'Hara, 1994, Market statistics and technical analysis: The role of volume. *Journal of Finance* **49**, 153-181.
- Brock, W. A. and A. W. Kleidon, 1992, Periodic market closure and trading volume. *Journal of Economic Dynamics and Control* **16**, 451-489.
- Brown, D. and R. Jennings, 1989, On technical analysis. *Review of Financial Studies* **2**, 527-551.
- Campbell, J. Y., S. J. Grossman, and J. Wang, 1993, Trading volume and serial correlation in stock returns. *Quarterly Journal of Economics*, 905-939.
- Cao, C., H. Choe, and F. Hatheway, 1994, What is special about the opening: Evidence from NASDAQ. *Working Paper*, The Pennsylvania State University.
- Choe, H. and H. S. Shin, 1993, An analysis of interday and intraday return volatility - Evidence from the Korea stock exchange. *Pacific-Basin Finance Journal* **1**, 175-188.
- Foster, F. D. and S. Viswanathan, 1990, A theory of the interday variations in volume, variance, and trading costs in security markets. *Review of Financial Studies* **3**, 593-624.
- , 1993, Variations in trading volume, return volatility, and trading costs: Evidence on recent price formation models. *Journal of Finance* **48**, 187-211.
- French, K. R., 1980, Stock returns and the weekend effect. *Journal of Financial Economics* **8**, 55-69.
- French, K. R. and R. Roll, 1986, Stock return variances: The arrival of information and the reaction of traders. *Journal of Financial Economics* **17**, 5-26.

- Gerety, M. S. and J. H. Mulherin, 1992, Trading halts and market activity: An analysis of volume at the open and the close. *Journal of Finance* **47**, 1765-1784.
- , 1994, Price formation on stock exchanges: The evolution of trading within the day. *Review of Financial Studies* **7**, 609-629.
- Grossman, S. J. and M. H. Miller, 1988, Liquidity and market structure. *Journal of Finance* **43**, 617-633.
- Grundy, B. D. and M. McNichols, 1989, Trade and the revelation of information through prices and direct disclosure. *Review of Financial Studies* **2**, 495-526.
- Hansen, L., 1982, Large sample properties of generalized method of moment estimators. *Econometrica* **50**, 1029-1054.
- Harris, L. E., 1990, Estimation of stock variances and serial covariances from discrete observations. *Journal of Financial and Quantitative Analysis* **25**, 291-306.
- Harris, M. and A. Raviv, 1993, Differences of opinion make a horse race. *Review of Financial Studies* **6**, 473-506.
- Jain, P. C. and G. Joh, 1988, The dependence between hourly prices and trading volume. *Journal of Financial and Quantitative Analysis* **23**, 269-283.
- Jones, C. M. and G. Kaul, 1994, On the use of variance ratios. *Working Paper*, University of Michigan.
- Keim, D. and R. Stambaugh, 1984, A further investigation of weekend effect in stock returns. *Journal of Finance* **39**, 819-835.
- Kim, C. and J. Park, 1994, Holiday effects and stock returns: Further evidence. *Journal of Financial and Quantitative Analysis* **29**, 145-157.
- Kyle, A. S., 1985, Continuous auctions and insider trading. *Econometrica* **53**, 1315-1335.
- Lakonishok, J. and E. Maberly, 1990, The weekend effect: Trading patterns of individual and institutional investors. *Journal of Finance* **45**, 231-243.
- Lin, W. L., R. F. Engle, and T. Ito, 1994, Do bulls and bears move across borders? International transmission of stock returns and volatility. *Review of Financial Studies* **7**, 507-538.
- Madhavan, A., 1992, Trading mechanisms and securities markets. *Journal of Finance* **47**, 607-643.
- Masulis, R. and V. Ng, 1992, Overnight and daytime return dynamics on the London stock exchange. *Working paper*, Vanderbilt University.
- Newey, W. and K. West, 1987, A simple, positive semi-definite, heteroskedasticity, and autocorrelation consistent covariance matrix. *Econometrica* **55**, 703-708.
- Richardson, M. and T. Smith, 1991, Tests of financial models in the presence of overlapping observations. *Review of Financial Studies* **4**, 227-254.
- Ronen, T., 1994, Tests and properties of variance ratios in microstructure studies. *Working paper*, University of Wisconsin.
- Roll, R., 1984, A simple implicit measure of the effective bid-ask spread in an efficient market. *Journal of Finance* **39**, 1127-1139.
- Scholes, M. and J. Williams, 1997, Estimating betas from nonsynchronous data. *Journal of Financial Economics* **5**, 309-327.
- Shalen, C., 1993, Volume, volatility, and the dispersion of beliefs. *Review of Financial Studies* **6**, 405-434.

Smith, T., 1994, Econometrics of financial models and market microstructure effects. *Journal of Financial and Quantitative Analysis* **29**, 519-540.

Stoll, H. and R. Whaley, 1983, Transaction costs and the small firm effect. *Journal of Financial Economics* **12**, 57-79.

———, 1990, Stock market structure and volatility. *Review of Financial Studies* **3**, 37-71.